

APPLICATION NOTE



HIGH PERFORMANCE 2 WAY, 8" LOUDSPEAKER SYSTEM

KEY FEATURES

- An effective, high performance and easy to build two way loudspeaker system for high performance in a very compact and portable enclosure.
- An “already optimized” passive crossover network greatly simplifies the system setup.

8NW650



General Specifications

Nominal Diameter	200mm (8 in)
Rated Impedance	8 Ohm
AES Power	300 W
Program Power	600 W
Peak Power	1200 W
Sensitivity	96 dB
Frequency Range	55 + 6300 Hz
Power Compression @-10dB	0,8 dB
Power Compression @-3dB	2,2 dB
Power Compression @Full Power	3,0 dB
Max Recomm. Frequency	2500 Hz
Recomm. Enclosure Volume	10 + 40 lt. (0,36 + 1,41 cuft)
Minimum Impedance	6,3 Ohm at 25°C
Max Peak To Peak Excursion	26 mm (1.02 in)
Voice Coil Diameter	65 mm (2.5 in)
Voice Coil Winding Material	Edgewound aluminum
Suspension	Triple roll, Polycotton
Cone	Curvilinear weather resistant treated paper

Thiele Small Parameters

Fs	63 Hz
Re	6,1 Ohm
Sd	0,0227 sq.mt. (35,19 sq.in.)
Qms	3,7
Qes	0,27
Qts	0,25
Vas	17,8 lt. (0.63 cuft)
Mms	26 gr. (0.06 lb)
BL	15,2 Tm
Linear Mathematical Xmax	± 5.5 mm (±0,22 in)
Le (1kHz)	0,71 mH
Ref. Efficiency 1W@1m (half space)	94,0 dB

ND1030



General Specifications

Throat Diameter	25,4 mm (1 in)
Rated Impedance	8 Ohm
DC Resistance	5,8 Ohm
Minimum Impedance	6,5 Ohm at 5000Hz
Le (at 1kHz)	54 µH
AES Power	30 W above 2 kHz
Program Power	60 W above 2 kHz
Sensitivity	107 dB
Frequency Range	1800Hz + 20kHz
Recomm. Xover Frequency	1800Hz 12dB/oct slope
Diaphragm Material	Titanium
Voice Coil Diameter	34,4 mm (1 1/3 in)
Voice Coil Winding Material	Edge-wound aluminum
Magnet Material	Neodymium
Flux Density	1,8 T
BL Factor	6 N/A
Polarity	Positive voltage on red terminal gives positive pressure in the throat

XT120



General Specifications

Throat Diameter	25,4 mm (1 in)
Horizontal Coverage -6db	90° (1 - -10) average range (2kHz - 12,5kHz)
Vertical Coverage -6db	60° (15 - -10) average range (2kHz - 12,5kHz)
Directivity Index	15 dB (2,5 - 1,5)
Usable Frequency Range	Above 1.5 kHz
Recomm. Xover Frequency	2 kHz or more
Sensitivity	108 dB
Frequency Range	2kHz - 18kHz
Material	Injection moulded Polyurethane

KEY FEATURES

- > The enclosure should be made out of Baltic birch plywood (15mm thick);
- > The vents can be made with standard PVC plumbing pipe connection with internal diameter of 48mm;
- > M5 T-Nuts in conjunction with M5x35mm Bolts is recommended;
- > Handling, rigging and connectors are user's choice;
- > It's recommended to well damping the cabinet as show in the example;
- > An high density dampening material, such as Dacron or other synthetic fibers, is required for best acoustic performance;



INTERNAL VIEW



DAMPING DISPOSITION

MEASUREMENTS: 8NW650 + ND1030 ON XT120

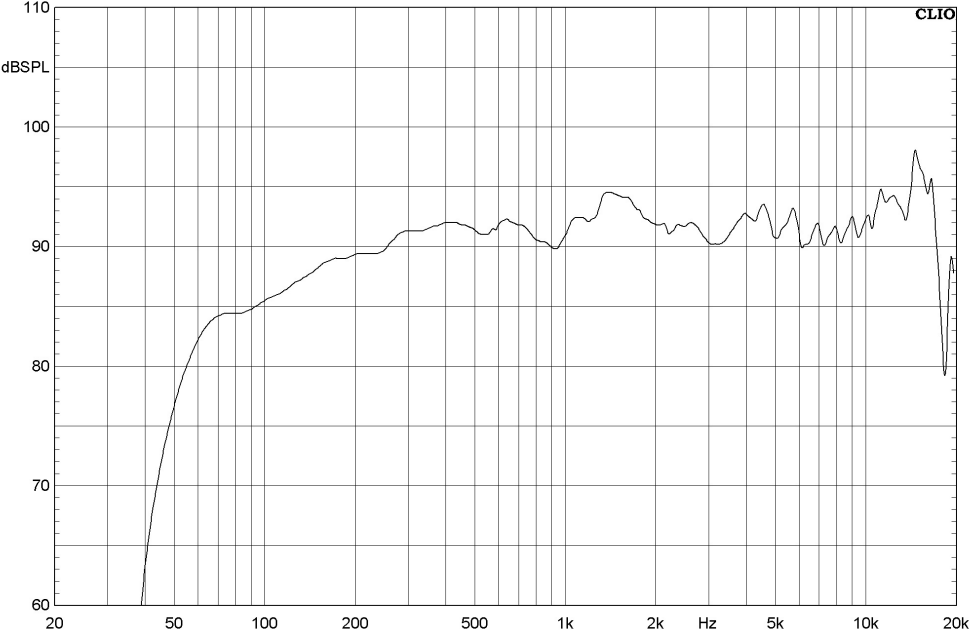

MAGNITUDE RESPONSE

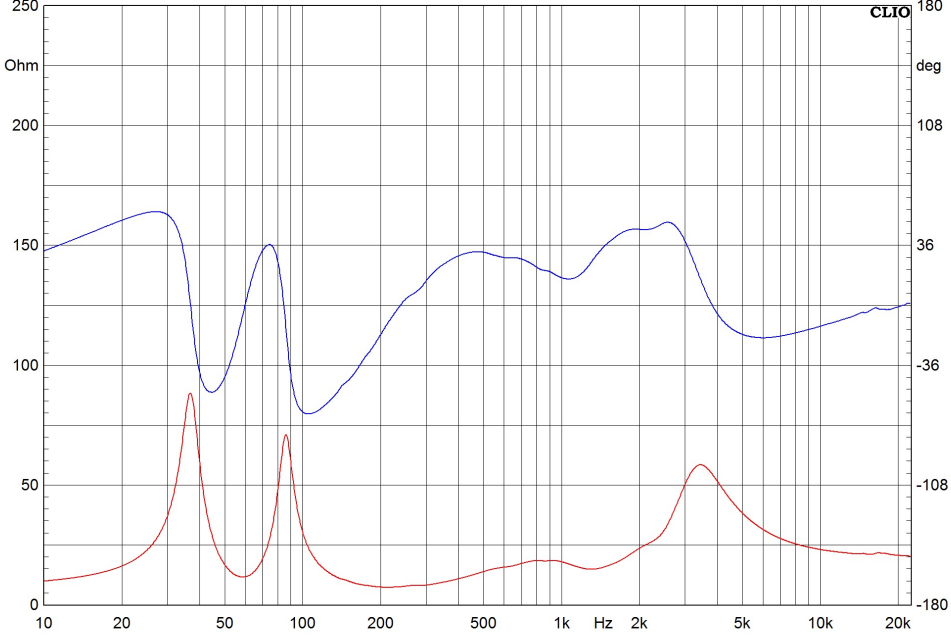

PHASE RESPONSE
IMPEDANCE

HORIZONTAL POLAR RESPONSE

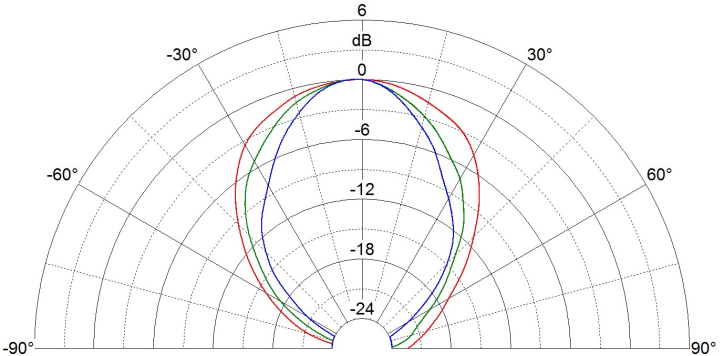
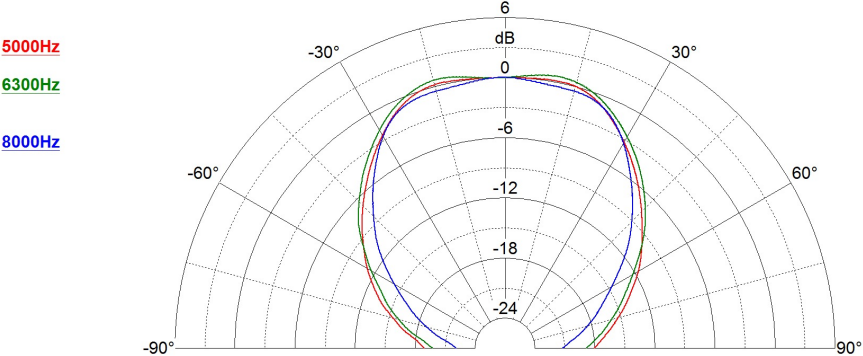
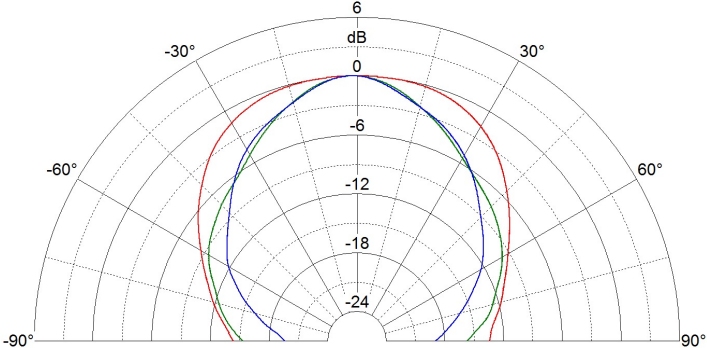
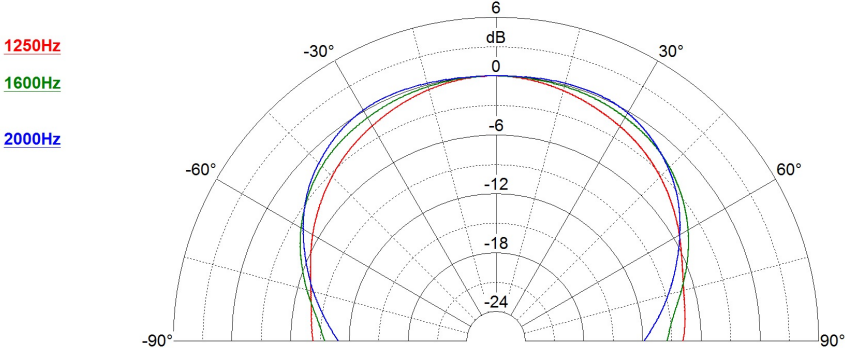

VERTICAL POLAR RESPONSE

1250Hz

1600Hz

2000Hz

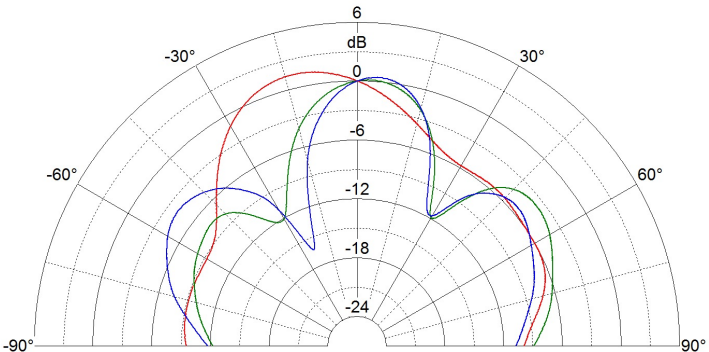

2500Hz

3150Hz

4000Hz

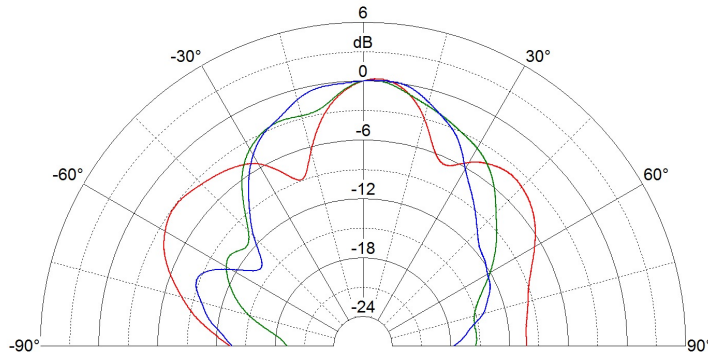

5000Hz

6300Hz

8000Hz

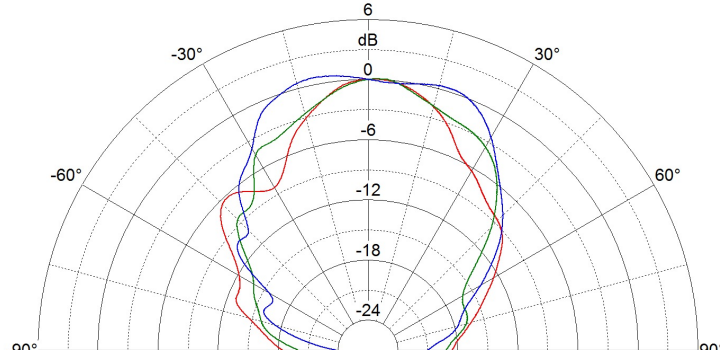

10000Hz

12500Hz

16000Hz

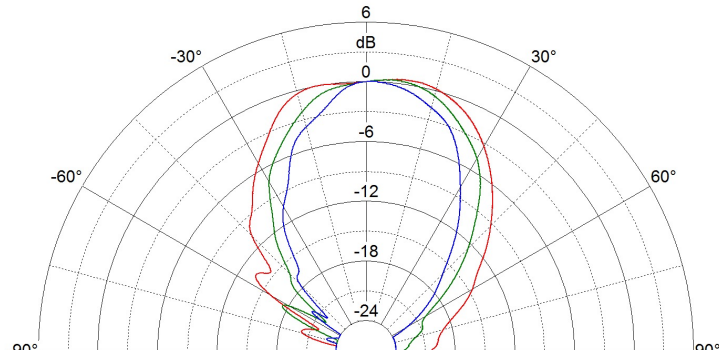

POLAR MAPS

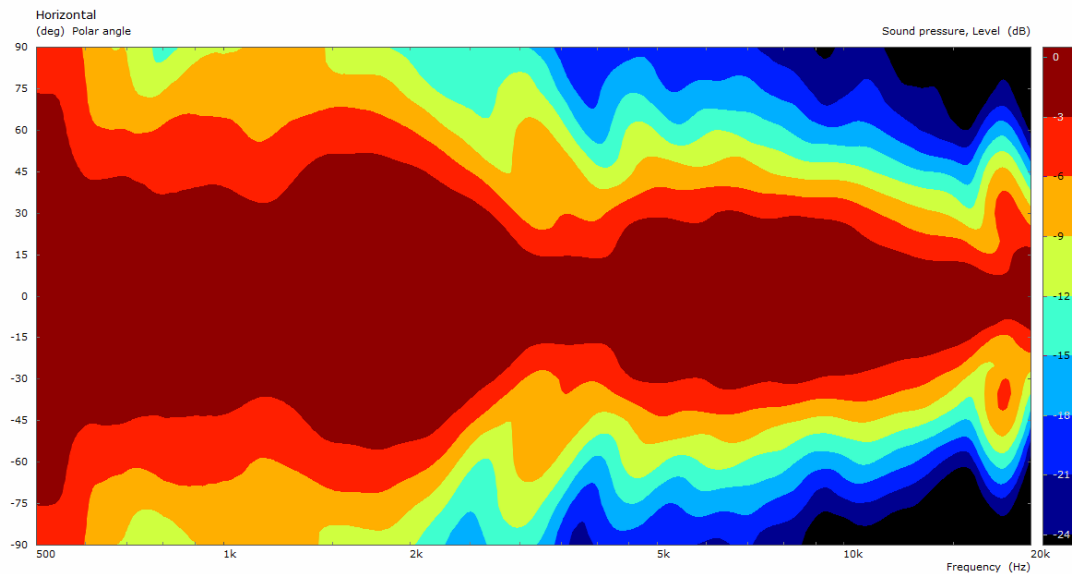

HORIZONTAL POLAR MAP

Normalized to 0deg Axis - 1/3 Smoothing

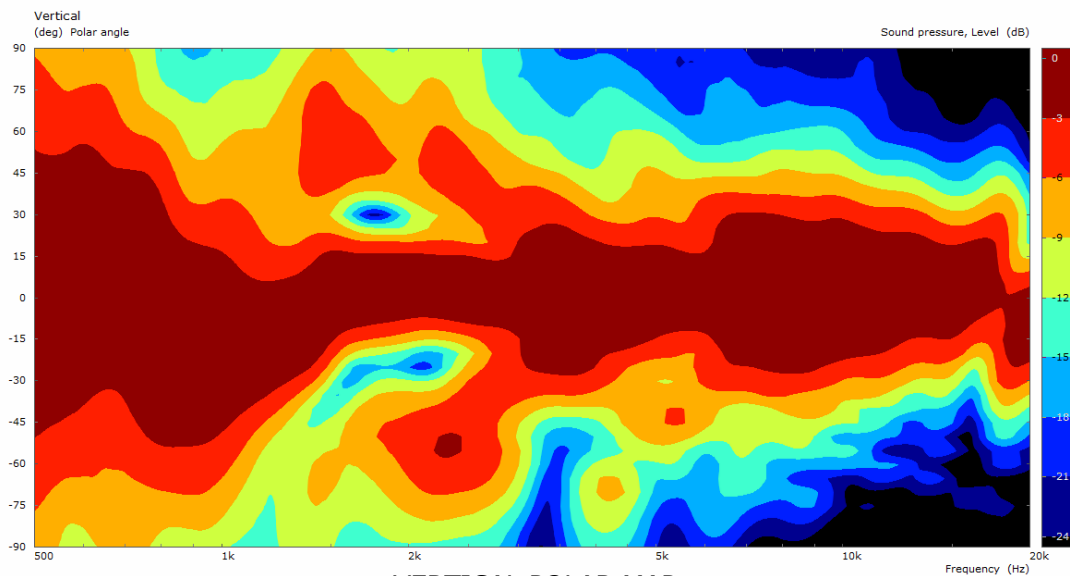

VERTICAL POLAR MAP

Normalized to 0deg Axis - 1/3 Smoothing

CROSSOVER SCHEMATICS

TYPE	VALUE	NOTE
L1 – Inductor	1.8 mH	
C1 – Capacitor	10 uF	5% - 250V
L2 – Inductor	1.5 mH	
C2 – Capacitor	8.2 Ohm	5% - 250V
R1 – Resistor	1 Ohm	10W
R2 – Resistor	12 Ohm	>20W
C3 – Capacitor	0.150 uF	5% - 100V
C4 – Capacitor	1.8 uF	5% - 250V
L3 – Inductor	0.680 mH	
R3 – Resistor	5.6 Ohm	10W

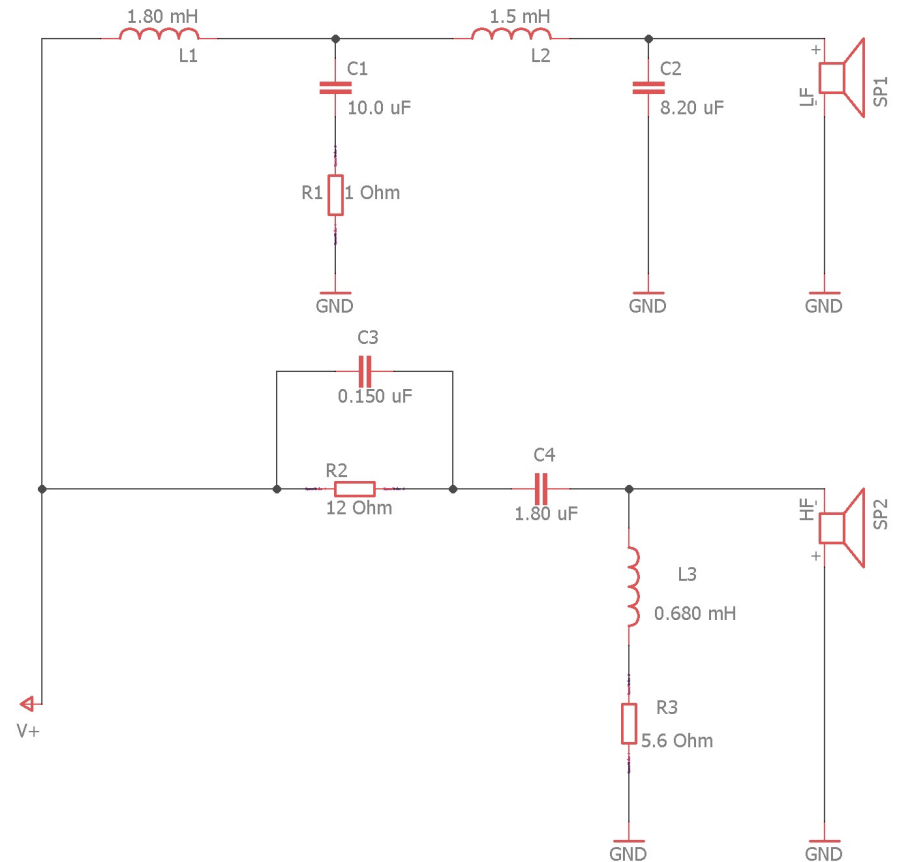

EXPLODED VIEW

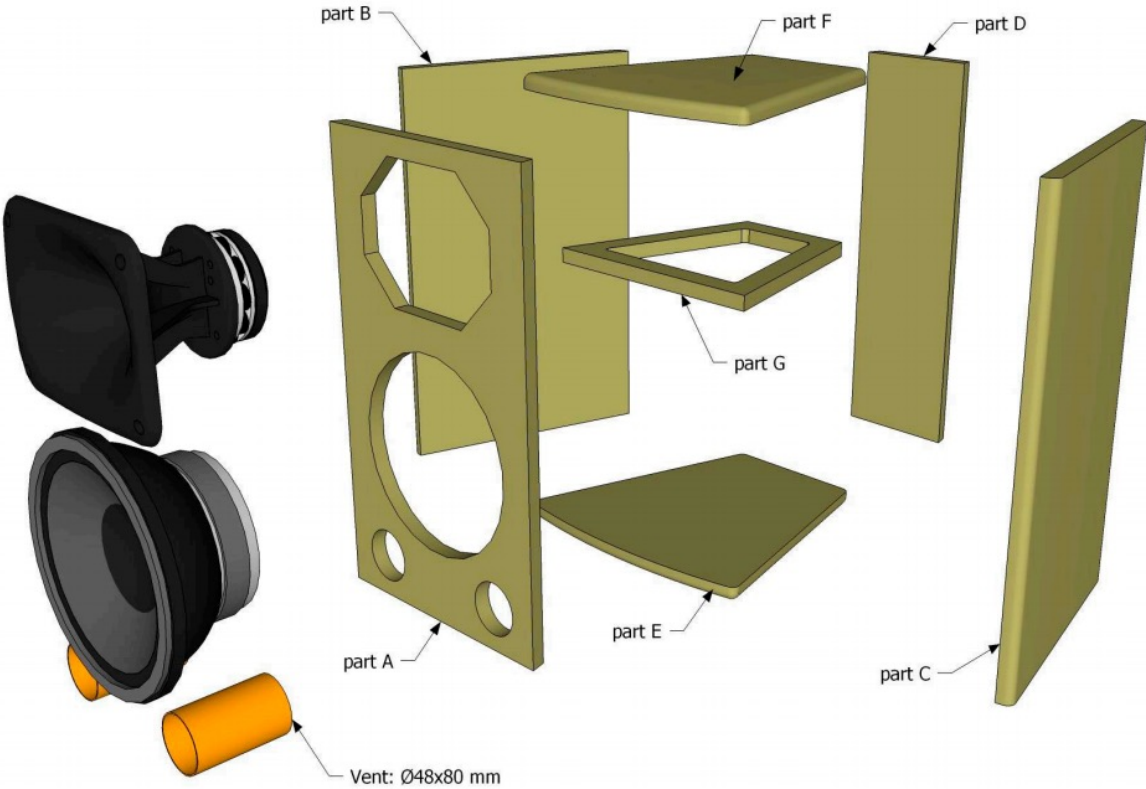

FRONT VIEW

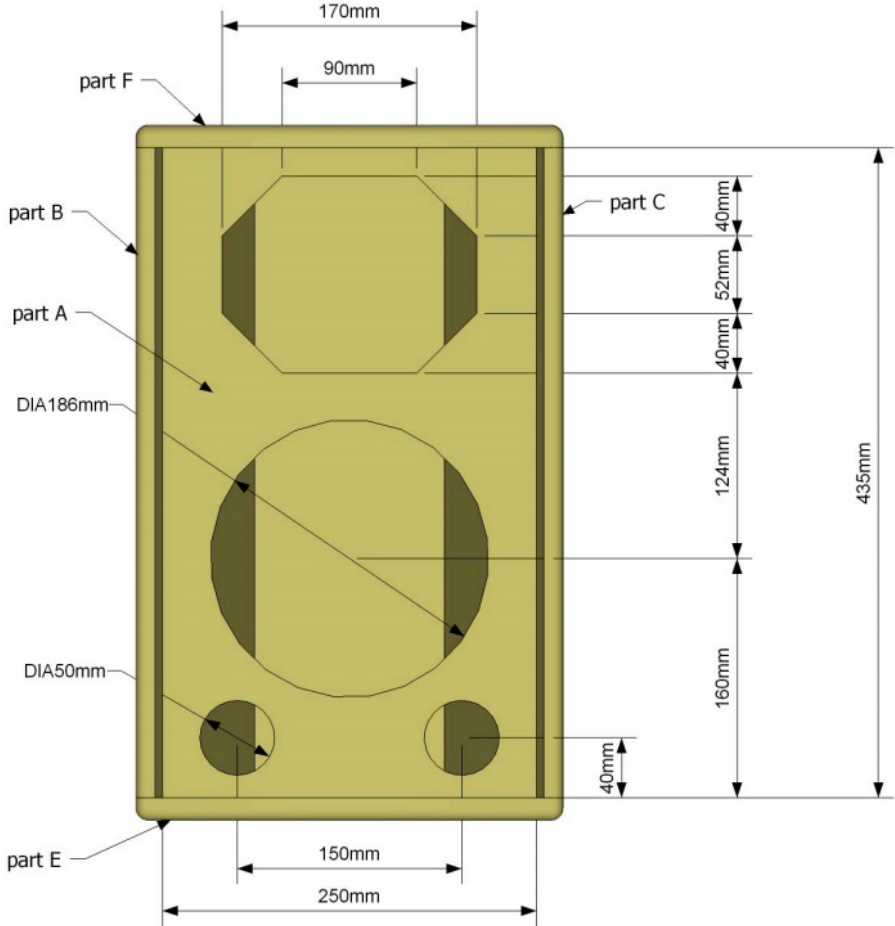

DETAILS: FRONT PANEL

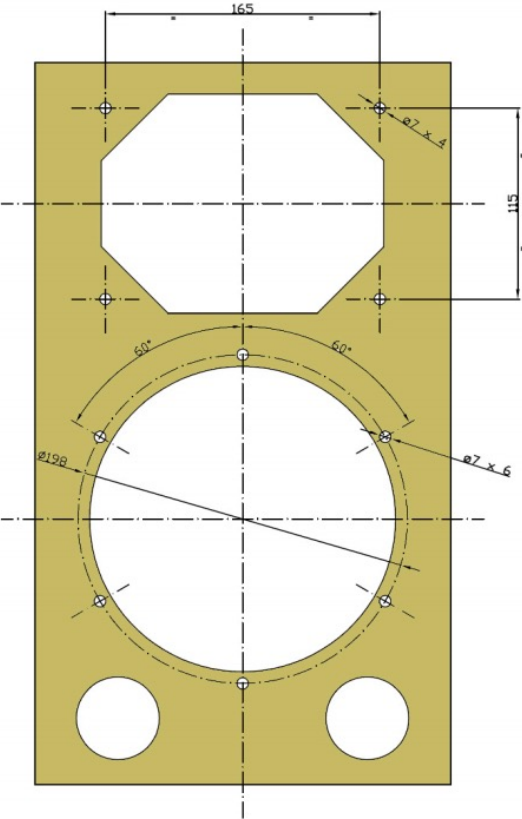

SIDE VIEW

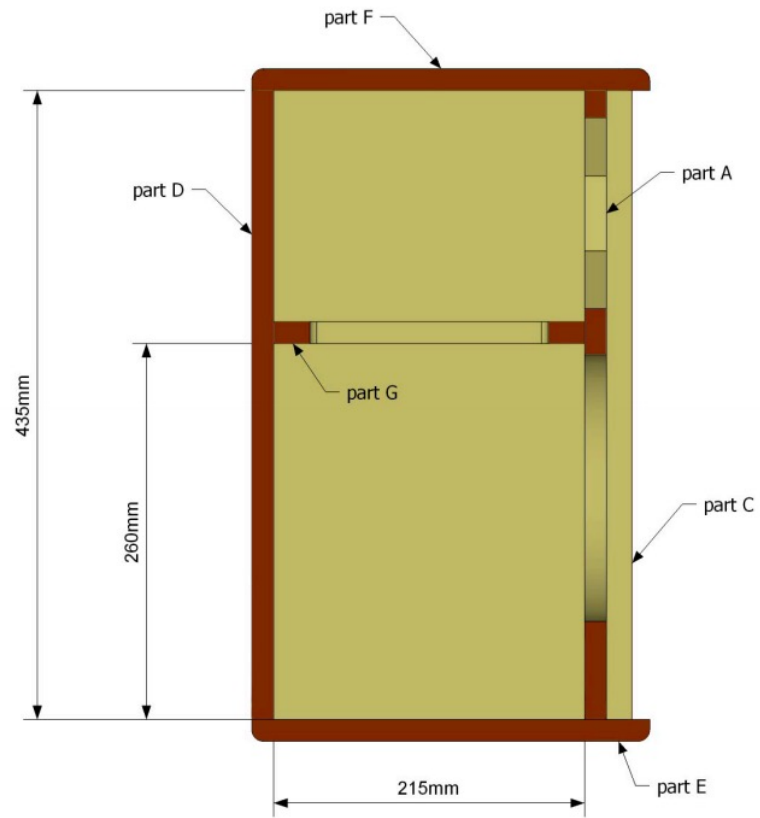

TOP VIEW

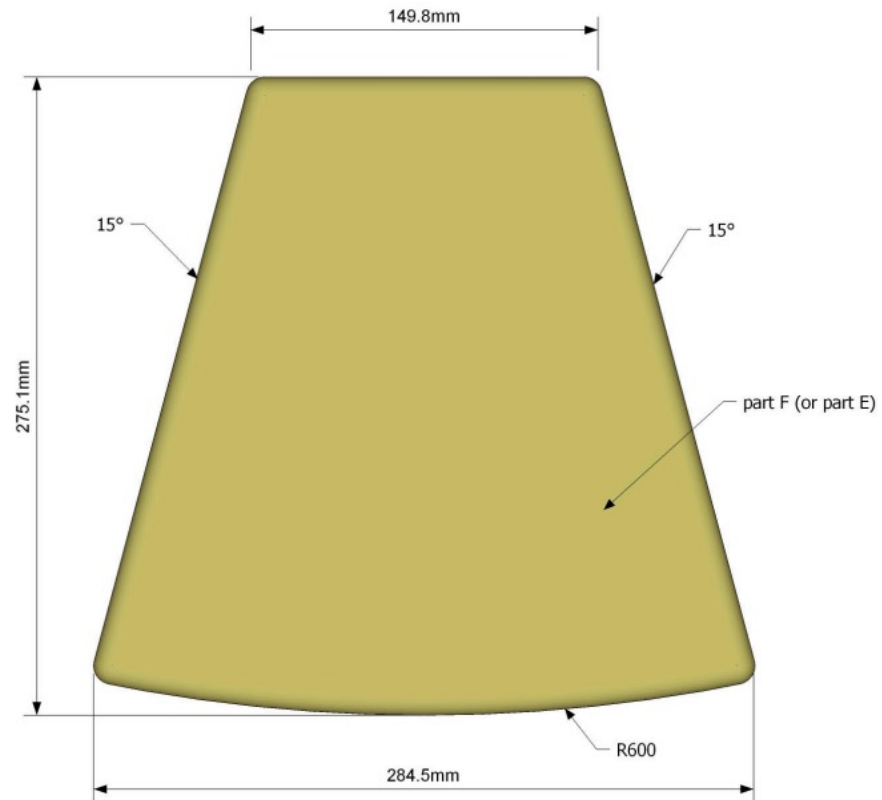

TOP SECTION: HORN HEIGHT

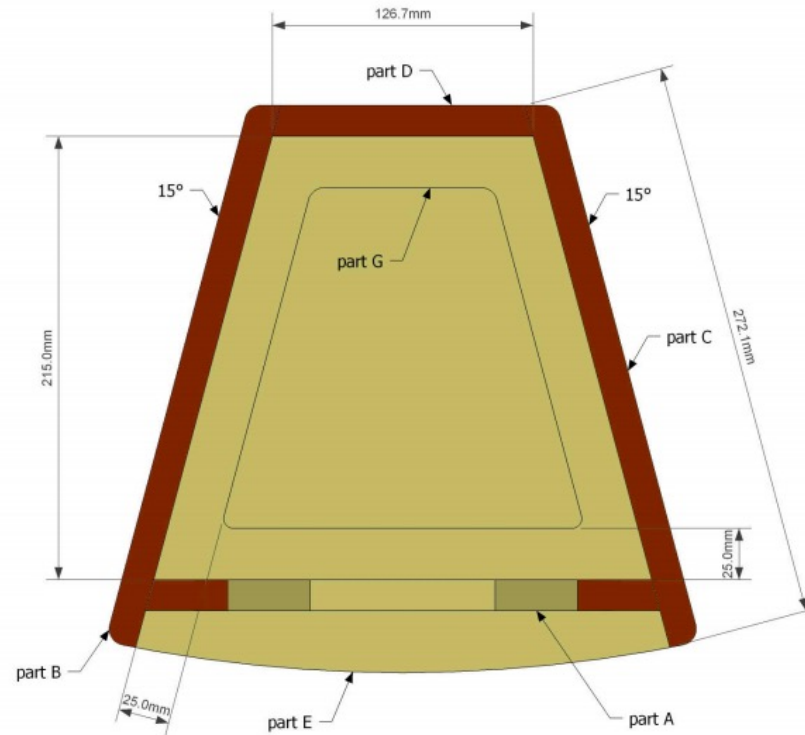

BACK VIEW

